

Rustic Scaffold Board Patio Set



Component List

TOOLS REQUIRED

Drill Driver / PZ2 Driver Bit / T25 Torx Bit / Tape Measure

Bench Seat (1200mm x 650mm x 790mm)

- 2 x 540mm Sawn Sleeper Foot Block (200mm x 100mm) (A)
- 2 x 650mm Scaffold Board Back Supports (225mm x 36mm) Angle Cut (B)
- 2 x 610mm Scaffold Board Frame Supports (225mm x 36mm) Angle Cut (C)
- 4 x 1200mm Scaffold Board Seat / Back Boards (225mm x 36mm) (D)

- 24 x 60mm Green Coated Screws (FIX 1)
- 4 x 150mm Frame Screws (FIX 2)



Chair (485mm x 650mm x 790mm)

- 1 x 540mm Sawn Sleeper Feet Block (200mm x 100mm) (A)
- 1 x 650mm Scaffold Board Back Supports (225mm x 36mm) Angle Cut (B)
- 2 x 610mm Scaffold Board Frame Supports (225mm x 36mm) Angle Cut (C)
- 2 x 450mm Scaffold Board Back Braces (225mm x 36mm) Angle Cut (E)
- 4 x 485mm Scaffold Board Seat / Back Boards (225mm x 36mm) (F)

- 20 x 60mm Green Coated Screws (FIX 1)
- 4 x 160mm Frame Screws (FIX 2)



Table (1200mm x 680mm x 360mm)

- 2 x 600mm Sawn Sleeper Feet Block (200mm x 100mm) (G)
- 2 x 600mm Scaffold Board Table Top Supports (225mm x 36mm) (H)
- 3 x 1200mm Scaffold Board Table Top (225mm x 36mm) (D)

- 12 x 60mm Green Coated Screws (FIX 1)
- 4 x 160mm Frame Screws (FIX 2)



All images are for illustration only. Please see individual item listings for actual item specifications.

Rustic Scaffold Board Patio Set



Bench Seat - Step 1

To start the build you must first create the two base pieces for the seat to sit on top of.

First measure 100mm to find the centre of the Foot Block (A) and fix into place 1 x Frame Support (C) using 2 x 150mm Frame Screws (FIX 2) driving through the bottom of the foot and into the underside of the support.

The back of the Frame Support (C) should be flush with the back and the front of the Foot Block (A) when it is the right direction see the diagram to the right for reference.

Repeat the process for both sides.

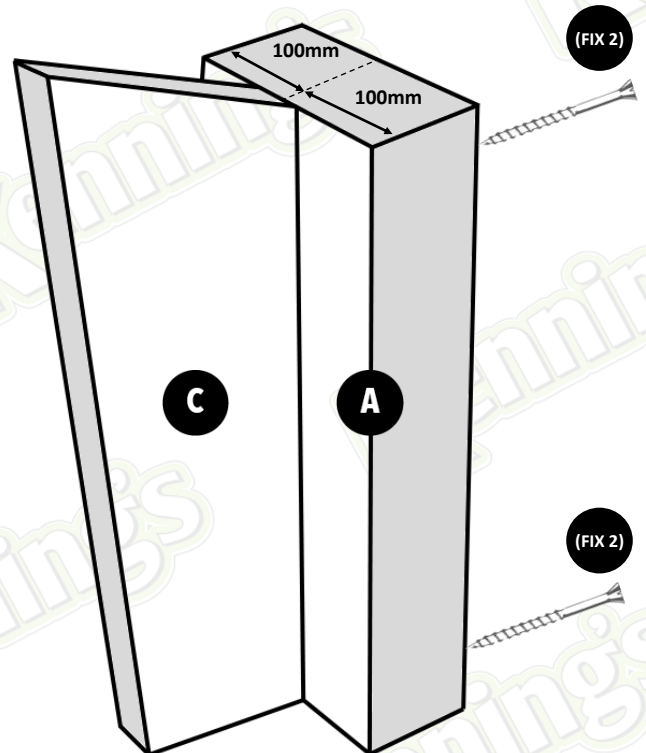

Bench Seat - Step 2

With (A) and (C) fixed together the Back Supports (B) can be added and secured into place with 4 x 60mm Green Coated Screws (FIX 1).

The long / back edge of the Back Supports (B) will be flush with the Frame Support (C) and the Foot Block (A).

Repeat the process for both sides.

Please Note: The Frame Supports (B) should be fixed to the inside of the Frame Support (C), see the rear view diagram for reference.

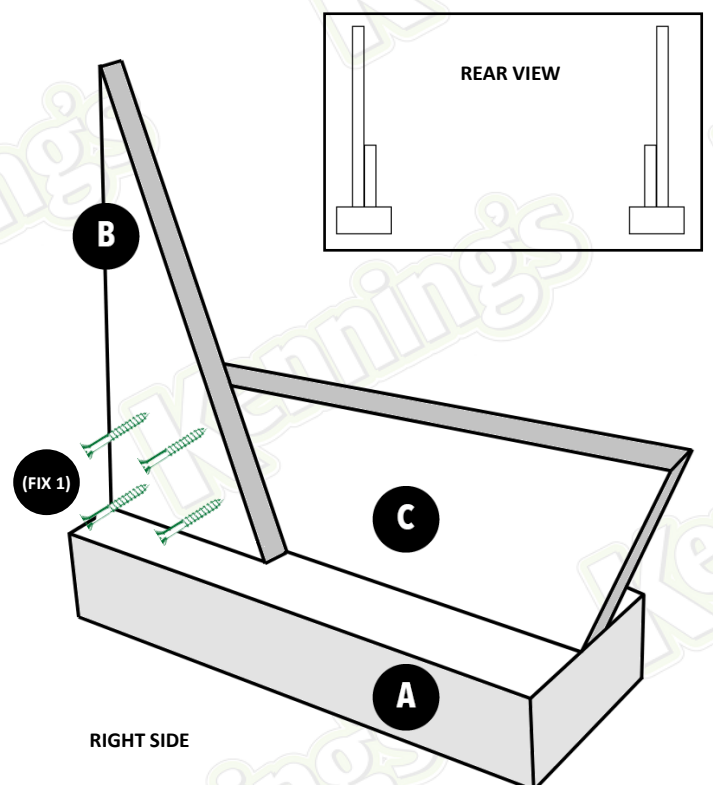

Bench Seat - Step 3

With the two supports / legs built, the final step is to screw down the 4 x Seat / Back Boards (**D**), these are secured into place using 2 x 60mm Green Coated Screws (**FIX 1**) per board, per end.

With the boards centralised on the two supports the screws will be driven in at the approximate below measurements:

- The seat boards screws will be 170mm from the ends.
- The back rest boards screws will be 205mm from the ends.

See below diagram for reference.

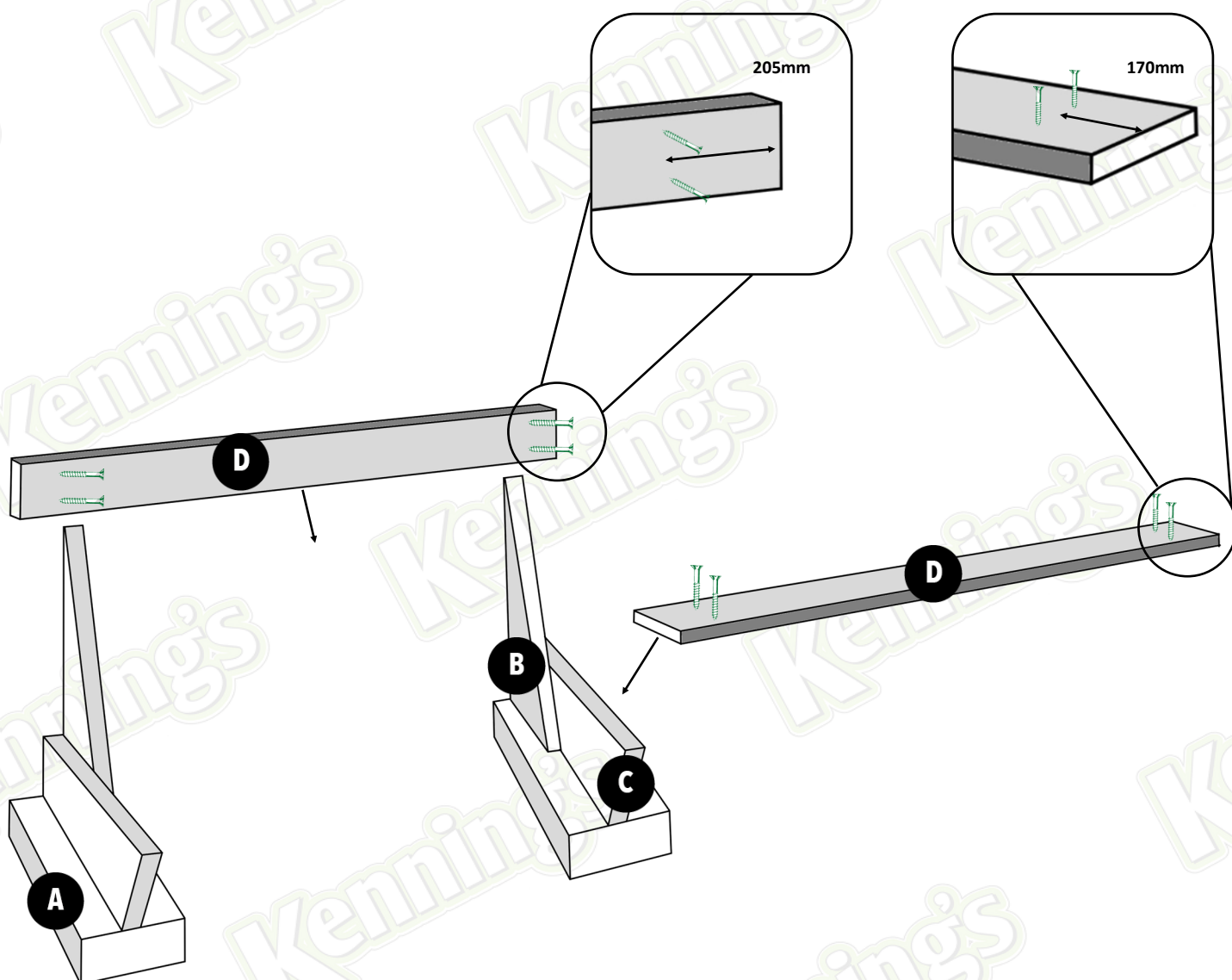

Rustic Scaffold Board Patio Set



Chair - Step 1

To start the build you must first create the two base pieces for the seat to sit on top of.

First measure 100mm to find the centre of the Foot Block (A) and fix into place 1 x Back Support (B) using 2 x 150mm Frame Screws (FIX 2) driving through the bottom of the foot and into the underside of the support.

The back of the Back Support (B) should be flush with the back and the front of the Foot Block (A) when it is the right position, see the diagram to the right for reference.

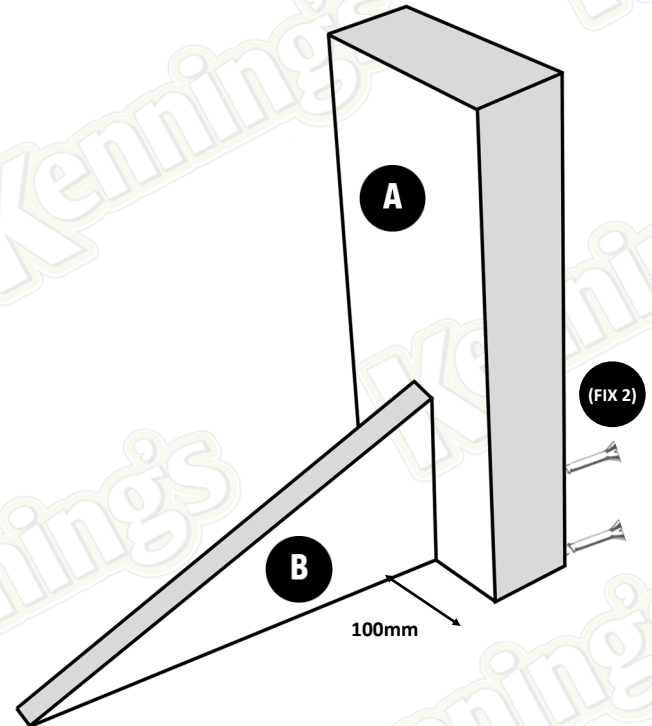

Chair - Step 2

With (A) and (B) fixed together the 2 x Seat Supports (C) can be added either side of the Back Support (B) and secured into place with 4 x 60mm Green Coated Screws (FIX 1) on each side.

The back edge of the Frame Supports (C) should be flush with the Back Support (B) and the Foot Block (A).

To secure the front of the Frame Supports (C) use 1 x 150mm Frame Screws (FIX 2) driving through the bottom of the Foot Block (A) and into the underside of the Frame Supports (C).

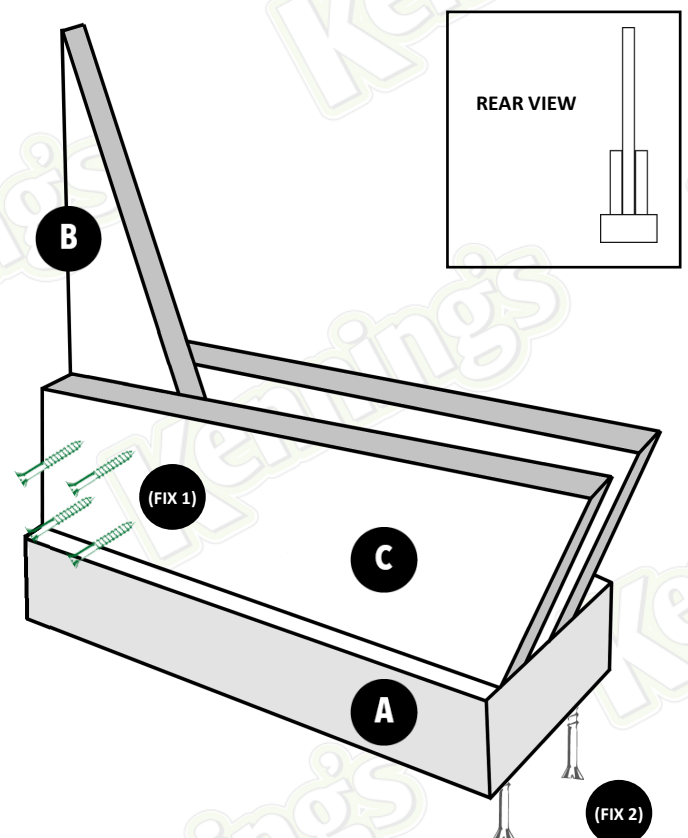

Chair - Step 3

With the primary chair base built, the final step before adding the seat and back rest boards is to screw into position the 2 x Back Braces (**E**) which will create the required additional strength and stability.

These two pieces are added to the sides the primary Back Support (**B**) and on top of the Frame Supports (**C**) are secured into place using 4 x 60mm Green Coated Screws (**FIX 1**) per board, per end.

The 2 x Back Braces (**E**) are triangular pieces that should match up and be flush all around with the Back Support (**B**).

See the diagram to the right for reference.

With the chair base built, the final step is to centralise the 4 x Seat / Back Boards (**F**) on the base unit and secure them into place using 4 x 60mm Green Coated Screws (**FIX 1**) per board, driving through the top of the board and into the seat base / back.

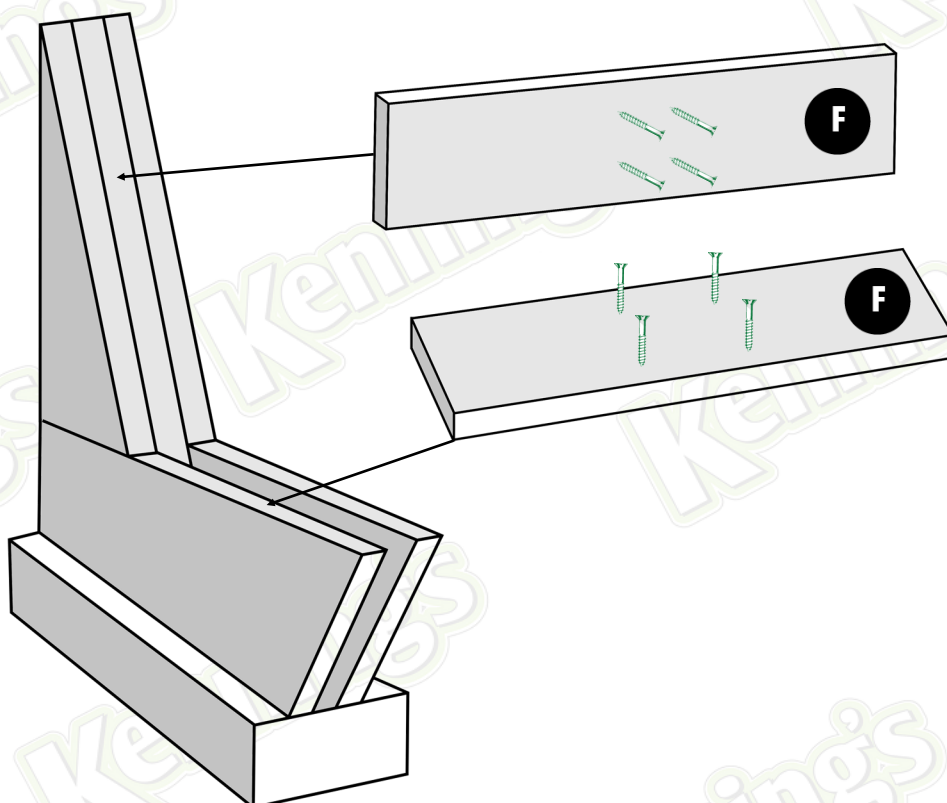
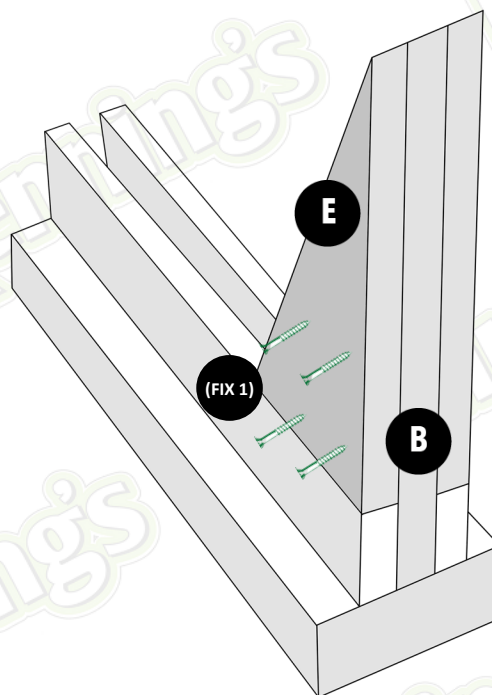

Rustic Scaffold Board Patio Set



Table - Step 1

To start the build you must first create the two base pieces for the table top to sit on top of.

First measure 100mm to find the centre of the Foot Block (G) and fix into place 1 x Table Top Support (H) using 2 x 150mm Frame Screws (FIX 2) driving through the bottom of the foot and into the underside of the support.

The back of the Table Top Support (H) should be flush with the back and the front of the Foot Block (G) when it is the right position, see the diagram to the right for reference.

Repeat the process for both legs / table top supports.

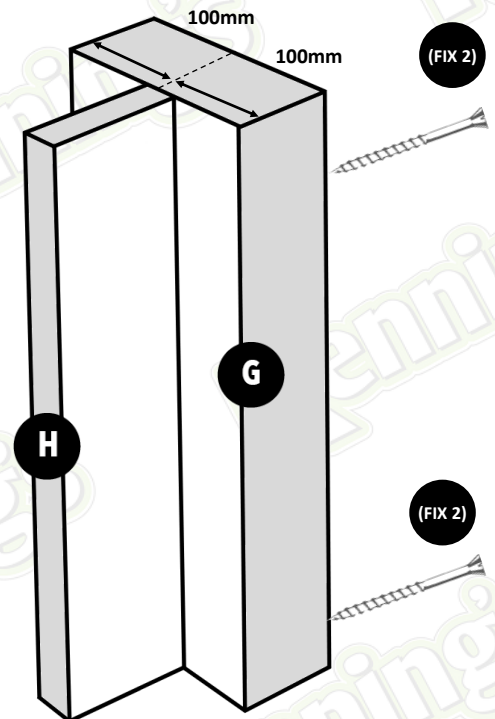

Table - Step 2

With the two legs / table top supports built all that is left to do is fix the Table Top boards (D) in place.

The 3 x Table Top boards (D) simply lay on top of the frame / base unit and are secured into place.

Use 4 x 60mm Green Coated Screws (FIX 1) per board, two at each end, driving through the top of the board and into the Table Top Support boards (H) below.

See the diagram to the right for reference in regards spacing.

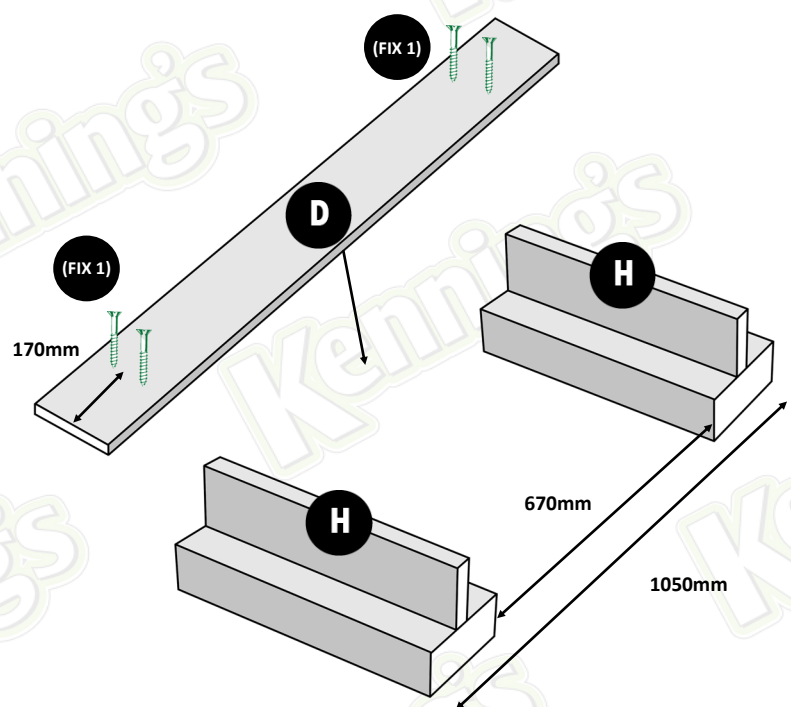

Rustic Scaffold Board Patio Set

Kennings's



**Enjoy your
Rustic Scaffold Board Patio Set**

All images are for illustration only. Please see individual item listings for actual item specifications.

Page 7 of 7